





VISION

Gama transparente de vitrinas y semivitrinas

Flexibilidad Implantación

- La gama se compone de vitrinas abiertas y cerradas y de semivitrinas abiertas con 1 y 2 estantes de cristal
- Se pueden colocar de forma individual, en línea y formando cuadrados

Diseño de líneas rectas que propicien la integración del mobiliario en la tienda

- Frontales y trasera transparentes
- Cristales exteriores templados y laterales panorámicos

VISION

Trasnparente range of promotional display counters and low mutidecks

Flexibility layout

- The range consists of open and closed display counters and low multidecks with 1 and 2 glass shelves.
- They can be positioned individually, in line and in squares.

Straight-lined design to facilitate the integration of the display cases into the shop

- Transparent front and back panels
- Exterior tempered glass and panoramic sides

VISION

Gama transparente de vitrinas y semivitrinas promocional Plug-in R290
Plug-in R290 transparent range of promotional display counter and low multidecks.





VISION

Gama transparente de vitrinas y semivitrinas promocional Plug-in R290

Plug-in R290 transparent range of promotional display counter and low multidecks.

Gama transparente de vitrinas y semivitrinas de uso promocional para potenciar la venta por impulso que aportan una visibilidad total del producto expuesto

- Régimen de Tª Temperatura M2
 - Tª producto: -1°C/+7°C
 - Tª aplicación: +2°C/+4°C
- Clase Climática
 - Clase 3 (25°C / 60% HR)
- Cristal frontal fijo templado
- Estantes:
 - SVS E1: Estante de cristal templado (350 mm)
 - SVS E2: 2 estantes de cristal templado (350 y 250 mm)
- Colores:
 - Exterior: Negro
 - Interior: Transparente con exposición en color negro
- Decoraciones y estructura en chapa pintada en epoxi
- Refrigerante R290 (Propano)
- Evaporación de agua automática
- Ventiladores electrónicos
- Desescarche natural
- Control electrónico

Transparent range of promotional display counters and low multidecks for impulse sales that provide total visibility of the product on display

- Temperature range M2
 - Tª producto: -1°C/+7°C
 - Tª aplicación: +2°C/+4°C
- Climate class
 - Clase 3 (25°C / 60% HR)
- Toughened fixed front glass
- Shelves
 - Toughened glass shelf
 - (350 y 250 mm) 2 Toughened glass shelves
- Colors
 - Exterior: Black
 - Transparent with black Exposition deck
- Epoxy painted sheet metal decorations and structure
- Refrigerant R290 (Propane)
- Automatic water evaporation
- Electronic fans
- Natural defrosting
- Electronic control



SVS E1

Infrico
Supermarket

Rango de temperaturas / Temperature range

Tº Prod.	Tº Aplic.
M2: -1/+7°C	+2/+4°C



Charcutería
Deli



Bebidas
Cold drinks



Lacteos
Dairy

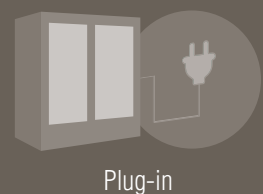

Dimensiones / Dimensions

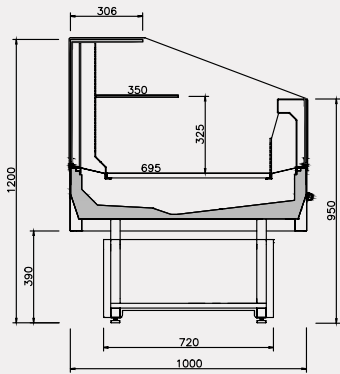

SVS_E1

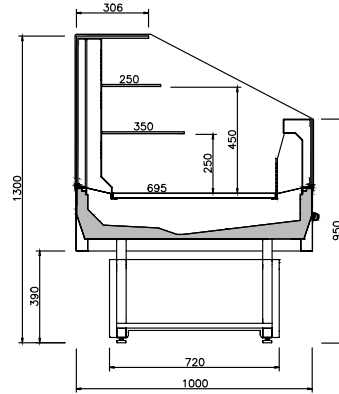

SVS_E2

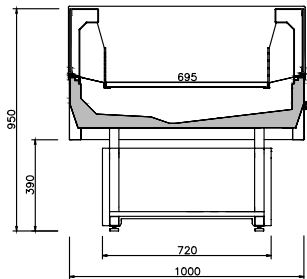

VWS



SVS E2

VSS

Modelos / Models

MODELO/MODEL		
VWS	10	12
SVS E1	10	12
SVS E2	10	12

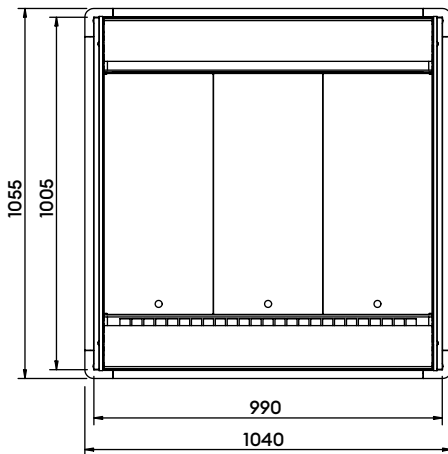

WS/SVS10

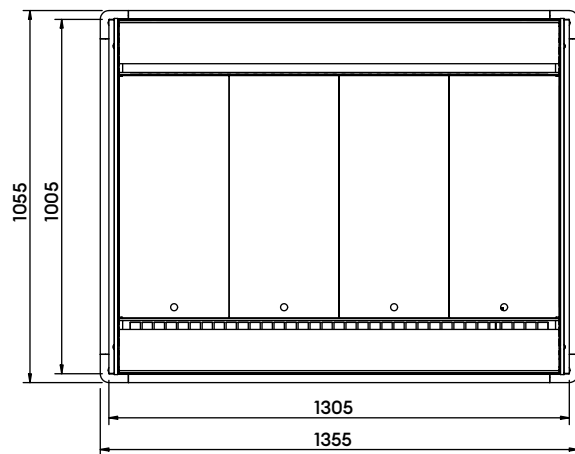

WS/SVS12